

# SPROCKETS



## Types and Materials

Correct engagement between roller chain and sprocket is required for smooth transmission of roller chain.

Appropriate selection of number of teeth (speed ratio), center-to-center distance, and arrangement of sprockets is crucial for service life of a roller chain and a sprocket. Pay due consideration to the selection of sprockets to avoid decreasing smooth rotation and transmission efficiency.

## Finished Sprockets

FBN (finished for new JIS key) and FB (finished for old JIS key) sprockets are a version, finished with shaft bore, key groove, and set screw, of KCM standard sprocket B-type.

Centralized production system is employed to ensure high precision and stable quality of products which are manufactured in the excellent facilities under stringent quality control. A thousand kinds of line-ups in total allows to satisfy user's needs and reduce the total cost.

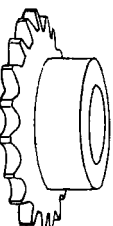
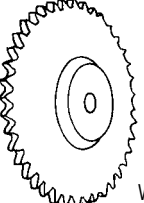
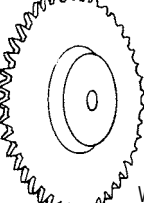
Type		Material
A-type	 <p>Steel plate sprocket</p>	<ul style="list-style-type: none"> <li>◦ Carbon steel for machine structural use</li> <li>▫ Common steel</li> </ul>
B-type	 <p>Machined</p> <p>Sprocket for chains with a small number of teeth, provided with standard hub diameter and hub width for the diameter of shaft employed</p>	<ul style="list-style-type: none"> <li>◦ Carbon steel for machine structural use</li> <li>▫ Common steel</li> </ul>
	 <p>Welded</p> <p>Sprocket with hub welded</p>	<ul style="list-style-type: none"> <li>◦ Carbon steel for machine structural use</li> <li>▫ Common steel</li> </ul>
C-type	 <p>Welded</p> <p>Sprocket with hubs welded on both sides</p>	<ul style="list-style-type: none"> <li>▫ Common steel</li> </ul>

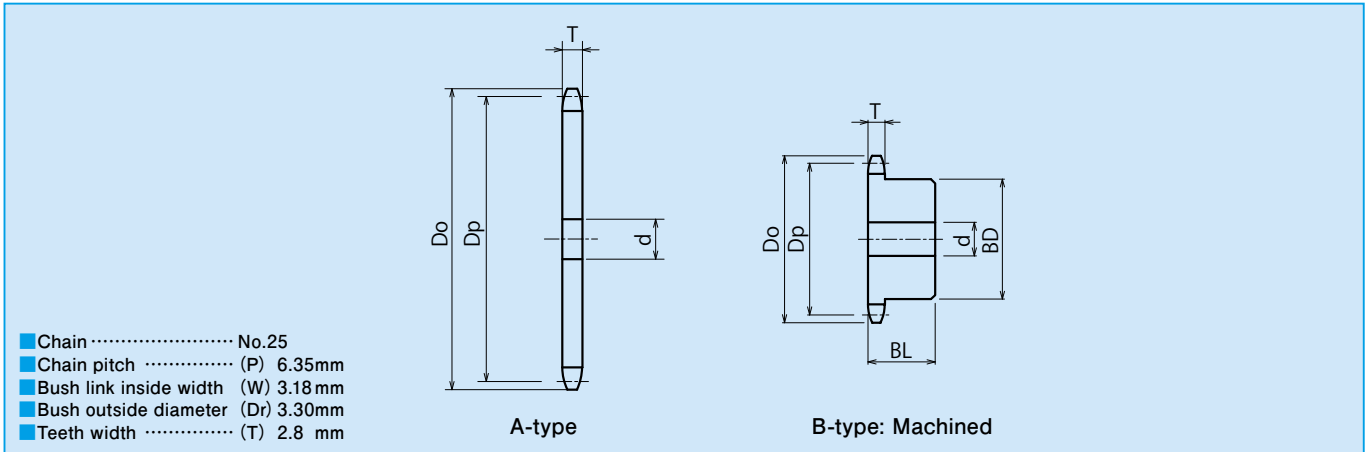

○ Dimensions

[Unit: mm]

TYPE (A-type)	No. of Teeth	Outside Dia. Do	Pitch Dia. Dp	Shaft Bore Dia. d		Weight (kg)
				Drill Hole	Min.	
25A	10	23	20.55	6	7	0.01
	12	28	24.53	7	8	0.01
	13	30	26.53	7	8	0.01
	14	32	28.54	7	8	0.01
	15	34	30.54	7	8	0.02
	16	36	32.55	9	10	0.02
	17	38	34.56	9	10	0.02
	18	40	36.57	9	10	0.02
	20	44	40.59	9	10	0.03
	24	52	48.65	9	10	0.04
	25	54	50.66	9	10	0.04
	27	58	54.70	9	10	0.05
	28	60	56.71	9	10	0.06
	29	62	58.73	9	10	0.06
	30	64	60.75	9	10	0.06
	32	68	64.78	10	11	0.07
	33	70	66.80	10	11	0.08
	35	74	70.84	10	11	0.09
	36	76	72.86	10	11	0.09
	37	78	74.88	10	11	0.10
38	80	76.90	10	11	0.10	
40	84	80.93	10	11	0.11	
42	89	84.97	11	12	0.12	
45	95	91.03	11	12	0.14	
50	105	101.13	11	12	0.18	
55	115	111.23	11	12	0.21	
60	125	121.33	11	12	0.25	
70	145	141.54	11	12	0.34	
75	155	151.64	11	12	0.40	
80	165	161.74	11	12	0.45	

TYPE (B-type)	No. of Teeth	Outside Dia. Do	Pitch Dia. Dp	Shaft Bore Dia. d			Hub Dia. BD	Hub Length BL	Weight (kg)	Construction	Material
				Drill Hole	Min.	Max.					
25B	10	23	20.55	6	7	8.5	14	15	0.03	Machined	Carbon steel for machine structural use
	11	25	22.54	7	8	8.5	15	15	0.03		
	12	28	24.53	7	8	9.5	15	15	0.03		
	13	30	26.53	7	8	10	18	15	0.05		
	14	32	28.54	7	8	10	20	15	0.05		
	15	34	30.54	7	8	10	20	15	0.05		
	16	36	32.55	9	10	12	25	15	0.06		
	17	38	34.56	9	10	12	25	15	0.07		
	18	40	36.57	9	10	12	25	15	0.07		
	19	42	38.58	9	10	16	28	15	0.08		
	20	44	40.59	9	10	16	28	15	0.08		
	21	46	42.61	9	10	16	28	15	0.09		
	22	48	44.62	9	10	16	30	15	0.10		
	23	50	46.63	9	10	16	30	15	0.11		
	24	52	48.65	9	10	16	30	15	0.12		
	25	54	50.66	9	10	20	35	15	0.14		
	26	56	52.68	9	10	20	35	15	0.14		
	27	58	54.70	9	10	20	35	15	0.15		
	28	60	56.71	9	10	20	35	15	0.15		
	29	62	58.73	9	10	20	35	15	0.16		
30	64	60.75	9	10	20	35	15	0.16			
31	66	62.77	10	11	22	40	20	0.20			
32	68	64.78	10	11	22	40	20	0.20			
33	70	66.80	10	11	22	40	20	0.21			
34	72	68.82	10	11	22	40	20	0.21			
35	74	70.84	10	11	22	40	20	0.21			
36	76	72.86	10	11	22	40	20	0.22			
37	78	74.88	10	11	22	40	20	0.26			
38	80	76.90	10	11	22	40	20	0.26			
39	82	78.91	10	11	22	40	20	0.27			
40	84	80.93	10	11	22	40	20	0.27			
41	87	82.95	11	12	30	50	20	0.32			
42	89	84.97	11	12	30	50	20	0.32			
43	91	86.99	11	12	30	50	20	0.40			
44	93	89.01	11	12	30	50	20	0.41			
45	95	91.03	11	12	30	50	20	0.41			
48	101	97.09	11	12	30	50	20	0.43			
50	105	101.13	11	12	30	50	20	0.46			
54	113	109.21	11	12	30	50	20	0.47			
60	125	121.33	11	12	30	50	20	0.52			
65	135	131.43	12	13	30	50	30	0.72			
70	145	141.54	12	13	30	50	30	0.77			
75	155	151.64	12	13	30	50	30	0.82			
80	165	161.74	12	13	30	50	30	0.88			

NOTES: - Material of A-type is all common steel.  
 - Shaft bore, key, tap, and the like will be processed to meet your request.  
 - Sprockets other than those listed above are also manufactured. Contact us.

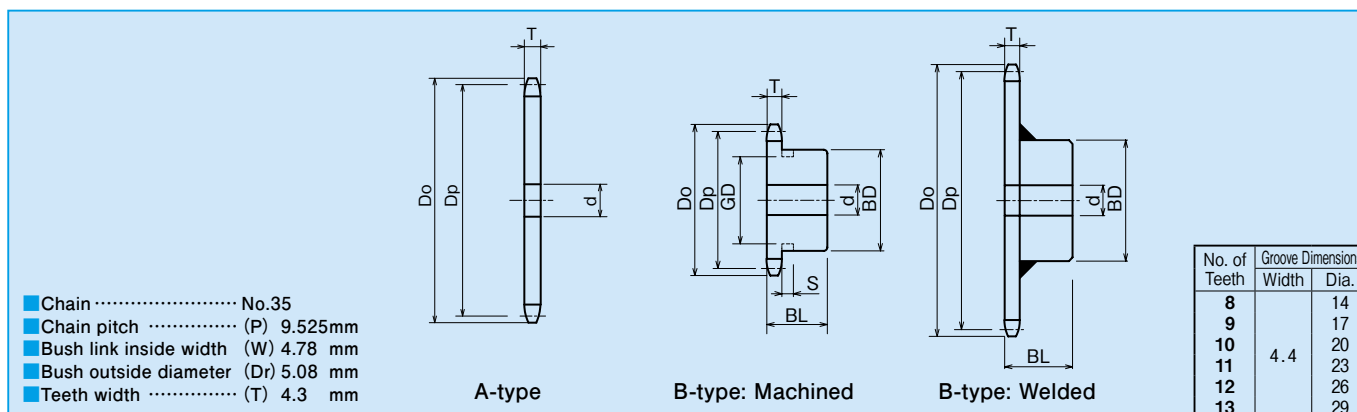

- Chain ..... No.35
- Chain pitch ..... (P) 9.525mm
- Bush link inside width (W) 4.78 mm
- Bush outside diameter (Dr) 5.08 mm
- Teeth width ..... (T) 4.3 mm

○ Dimensions

[Unit: mm]

TYPE (A-type)	No. of Teeth	Outside Dia. Do	Pitch Dia. Dp	Shaft Bore Dia. d		Weight(kg)
				Drill Hole	Min.	
35A	10	35	30.82	8	9	0.02
	11	38	33.81	8	9	0.03
	12	41	36.80	9	10	0.03
	13	44	39.80	9	10	0.04
	14	47	42.81	9	10	0.04
	15	51	45.81	9	10	0.05
	16	54	48.82	9	10	0.05
	17	57	51.84	11	12	0.07
	18	60	54.85	11	12	0.07
	19	63	57.87	11	12	0.09
	20	66	60.89	11	12	0.09
	21	69	63.91	11	12	0.11
	22	72	66.93	11	12	0.11
	23	75	69.95	11	12	0.11
	24	78	72.97	11	12	0.14
	25	81	76.00	11	12	0.16
	26	84	79.02	11	12	0.16
	27	87	82.05	11	12	0.17
	28	90	85.07	11	12	0.18
	30	96	91.12	11	12	0.23
	32	102	97.18	11	12	0.27
	33	105	100.20	11	12	0.28
	34	109	103.23	11	12	0.29
	35	112	106.26	11	12	0.30
	36	115	109.29	12	13	0.32
	38	121	115.34	12	13	0.37
	40	127	121.40	12	13	0.40
	42	133	127.46	14	15	0.43
	45	142	136.55	14	15	0.49
	46	145	139.58	14	15	0.51
	48	151	145.64	14	15	0.55
	50	157	151.70	14	15	0.60
54	169	163.81	14	15	0.70	
55	172	166.85	14	15	0.71	
60	187	182.00	14	15	0.80	
65	203	197.15	16	17	1.02	
70	218	212.30	16	17	1.18	
80	248	242.61	16	17	1.50	

TYPE (B-type)	No. of Teeth	Outside Dia. Do	Pitch Dia. Dp	Shaft Bore Dia. d			Hub Dia. BD	Hub Length BL	Weight (kg)	Construction	Material
				Drill Hole	Min.	Max.					
35B	8	29	24.89	8	9	10	★18.5	20	0.06	Machined	Carbon steel for machine structural use / Induction hardened tooth end
	9	32	27.85	8	9	11	★21.5	20	0.06		
	10	35	30.82	8	9	12	★24.5	20	0.08		
	11	38	33.81	8	9	14	★27	20	0.09		
	12	41	36.80	9	10	16	★30.5	20	0.12		
	13	44	39.80	9	10	18	★32	20	0.12		
	14	47	42.81	9	10	18	32	20	0.12		
	15	51	45.81	9	10	20	35	20	0.16		
	16	54	48.82	9	10	20	37	20	0.19		
	17	57	51.84	11	12	25	41	20	0.22		
	18	60	54.85	11	12	25	44	20	0.25		
	19	63	57.87	11	12	28	47	20	0.28		
	20	66	60.89	11	12	30	50	20	0.32		
	21	69	63.91	11	12	32	53	20	0.36		
	22	72	66.93	11	12	35	56	20	0.37		
	23	75	69.95	11	12	38	60	20	0.38		
	24	78	72.97	11	12	32	53	22	0.43		
	25	81	76.00	11	12	32	53	22	0.44		
	26	84	79.02	11	12	32	53	22	0.45		
	27	87	82.05	11	12	32	53	22	0.46		
	28	90	85.07	11	12	32	53	22	0.48		
	29	93	88.10	11	12	32	53	22	0.49		
	30	96	91.12	11	12	32	53	22	0.51		
	31	99	94.15	11	12	32	53	22	0.53		
	32	102	97.18	11	12	32	53	22	0.54		
	33	105	100.20	11	12	32	53	22	0.56		
	34	109	103.23	11	12	32	53	22	0.57		
	35	112	106.26	11	12	32	53	22	0.59		
	36	115	109.29	12	13	32	53	22	0.61		
	37	118	112.31	12	13	42	63	25	0.80		
	38	121	115.34	12	13	42	63	25	0.82		
	39	124	118.37	12	13	42	63	25	0.84		
	40	127	121.40	12	13	42	63	25	0.85		
	41	130	124.43	14	15	42	63	25	0.91		
	42	133	127.46	14	15	42	63	25	0.93		
	43	136	130.49	14	15	42	63	25	0.95		
	44	139	133.52	14	15	42	63	25	0.97		
	45	142	136.55	14	15	42	63	25	1.00		
	46	145	139.58	14	15	42	63	25	1.01		
	47	148	142.61	14	15	42	63	25	1.03		
48	151	145.64	14	15	42	63	25	1.05			
50	157	151.70	14	15	42	63	25	1.07			
53	166	160.78	14	15	42	63	25	1.09			
54	169	163.81	14	15	42	63	25	1.10			
55	172	166.85	14	15	42	63	25	1.25			
60	187	182.00	14	15	42	63	25	1.30			
64	200	194.12	16	17	42	63	25	1.46			
65	203	197.15	16	17	45	68	25	1.67			
70	218	212.30	16	17	45	68	25	1.80			
75	233	227.46	16	17	45	68	25	1.90			
80	248	242.61	16	17	45	68	25	2.40			

- NOTES: - Material of A-type is all common steel.  
 - Shaft bore, key, tap, and the like will be processed to meet your request.  
 - Sprockets other than those listed above are also manufactured. Contact us.  
 - Sprockets marked with star ★ are provided with groove on hub perimeter. See Groove Dimensions Table.

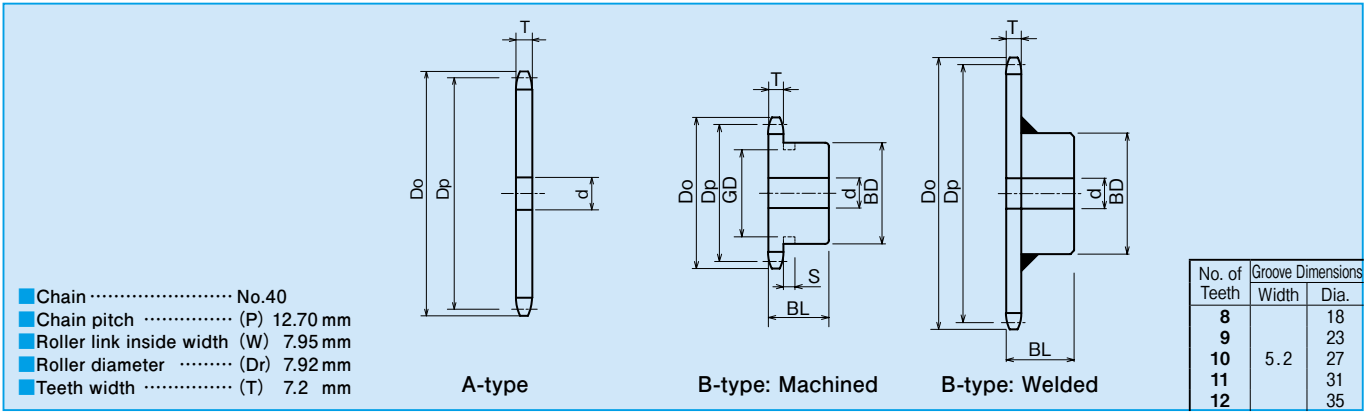

No. of Teeth	Groove Dimensions	
	Width	Dia.
8	5.2	18
9		23
10		27
11		31
12		35

○ Dimensions

[Unit: mm]

TYPE (A-type)	No. of Teeth	Outside Dia. Do	Pitch Dia. Dp	Shaft Bore Dia. d		Weight (kg)
				Drill Hole	Min.	
40A	10	47	41.10	9	10	0.05
	11	51	45.08	10	11	0.09
	12	55	49.07	10	11	0.10
	13	59	53.07	12	13	0.12
	14	63	57.07	12	13	0.14
	15	67	61.08	12	13	0.16
	16	71	65.10	13	14	0.18
	17	76	69.12	13	14	0.20
	18	80	73.14	13	14	0.23
	19	84	77.16	14	15	0.26
	20	88	81.18	14	15	0.29
	21	92	85.21	14	15	0.30
	22	96	89.24	14	15	0.35
	23	100	93.27	14	15	0.38
	24	104	97.30	14	15	0.40
	25	108	101.33	14	15	0.45
	26	112	105.36	14	15	0.49
	27	116	109.40	14	15	0.50
	28	120	113.43	14	15	0.56
	29	124	117.46	14	15	0.60
	30	128	121.50	14	15	0.63
	31	133	125.53	14	15	0.65
	32	137	129.57	14	15	0.70
	33	141	133.61	14	15	0.75
	34	145	137.64	14	15	0.80
	35	149	141.68	14	15	0.85
	36	153	145.72	16	17	0.90
	37	157	149.75	16	17	0.99
	38	161	153.79	16	17	1.00
	39	165	157.83	16	17	1.15
	40	169	161.87	16	17	1.20
	41	173	165.91	16	17	1.20
	42	177	169.95	16	17	1.25
	43	181	173.98	16	17	1.30
	44	185	178.02	16	17	1.35
	45	189	182.06	16	17	1.40
	46	193	186.10	16	17	1.49
	47	197	190.14	16	17	1.58
	48	201	194.18	16	17	1.63
	49	205	198.22	16	17	1.73
50	209	202.26	16	17	1.80	
51	214	206.30	16	17	1.88	
52	218	210.34	16	17	1.93	
53	222	214.38	16	17	1.98	
54	226	218.42	16	17	2.00	
55	230	222.46	16	17	2.18	
56	234	226.50	16	17	2.26	
58	242	234.58	16	17	2.43	
59	246	238.62	16	17	2.51	
60	250	242.66	16	17	2.60	
62	258	250.74	16	17	2.77	
64	266	258.83	16	17	2.90	
65	270	262.87	16	17	3.00	
68	282	274.99	16	17	3.35	
70	290	283.07	16	17	3.50	
72	299	291.16	20	21	3.70	
75	311	303.28	20	21	4.00	
80	331	323.49	20	21	4.60	
85	351	343.69	20	21	5.20	
90	371	363.90	20	21	5.80	

TYPE (B-type)	No. of Teeth	Outside Dia. Do	Pitch Dia. Dp	Shaft Bore Dia. d			Hub Dia. BD	Hub Length BL	Weight (kg)	Construction	Material
				Drill Hole	Min.	Max.					
40B	8	39	33.19	9	10	14	★24	22	0.10	Machined	Carbon steel for machine structural use / Induction hardened tooth end
	9	43	37.13	9	10	16	★28	22	0.11		
	10	47	41.10	9	10	18	★32	22	0.14		
	11	51	45.08	10	11	20	★36	22	0.19		
	12	55	49.07	10	11	22	★40	22	0.22		
	13	59	53.07	12	13	20	37	22	0.23		
	14	63	57.07	12	13	25	42	22	0.28		
	15	67	61.08	12	13	28	46	22	0.34		
	16	71	65.10	13	14	30	50	22	0.40		
	17	76	69.12	13	14	32	54	22	0.46		
	18	80	73.14	13	14	35	57	22	0.51		
	19	84	77.16	14	15	40	62	22	0.59		
	20	88	81.18	14	15	45	67	25	0.76		
	21	92	85.21	14	15	48	71	25	0.85		
	22	96	89.24	14	15	51	75	25	0.95		
	23	100	93.27	14	15	51	77	25	1.00		
	24	104	97.30	14	15	42	63	25	0.84		
	25	108	101.33	14	15	42	63	25	0.88		
	26	112	105.36	14	15	42	63	25	0.92		
	27	116	109.40	14	15	42	63	25	0.96		
	28	120	113.43	14	15	42	63	25	1.00		
	29	124	117.46	14	15	42	63	25	1.00		
	30	128	121.50	14	15	42	63	25	1.10		
	31	133	125.53	14	15	45	68	28	1.20		
	32	137	129.57	14	15	45	68	28	1.30		
	33	141	133.61	14	15	45	68	28	1.30		
	34	145	137.64	14	15	45	68	28	1.30		
	35	149	141.68	14	15	45	68	28	1.40		
	36	153	145.72	16	17	45	68	28	1.50		
	37	157	149.75	16	17	45	68	28	1.55		
	38	161	153.79	16	17	45	68	28	1.60		
	39	165	157.83	16	17	45	68	28	1.65		
	40	169	161.87	16	17	45	68	28	1.70		
	41	173	165.91	16	17	48	73	32	2.00		
	42	177	169.95	16	17	48	73	32	2.05		
	43	181	173.98	16	17	48	73	32	2.10		
	44	185	178.02	16	17	48	73	32	2.17		
	45	189	182.06	16	17	48	73	32	2.25		
	46	193	186.10	16	17	48	73	32	2.30		
	47	197	190.14	16	17	48	73	32	2.37		
48	201	194.18	16	17	48	73	32	2.45			
49	205	198.22	16	17	48	73	32	2.51			
50	209	202.26	16	17	48	73	32	2.60			
51	214	206.30	16	17	48	73	32	2.65			
52	218	210.34	16	17	48	73	32	2.72			
53	222	214.38	16	17	48	73	32	2.80			
54	226	218.42	16	17	48	73	32	2.90			
55	230	222.46	16	17	48	73	32	2.96			
56	234	226.50	16	17	48	73	32	3.04			
60	250	242.66	16	17	48	73	32	3.40			
64	266	258.83	16	17	48	73	32	3.73			
65	270	262.87	16	17	55	83	32	4.10			
68	282	274.99	16	17	55	83	32	4.35			
70	290	283.07	16	17	55	83	32	4.57			
72	299	291.16	20	21	55	83	32	4.80			
75	311	303.28	20	21	55	83	32	5.10			
80	331	323.49	20	21	60	88	35	5.90			
85	351	343.69	20	21	60	88	35	6.50			
90	371	363.90	20	21	60	88	35	7.15			

NOTES: - Material of A-type is all common steel.  
 - Shaft bore, key, tap, and the like will be processed to meet your request.  
 - Sprockets other than those listed above are also manufactured. Contact us.  
 - Sprockets marked with star ★ are provided with groove on hub perimeter. See Groove Dimensions Table.

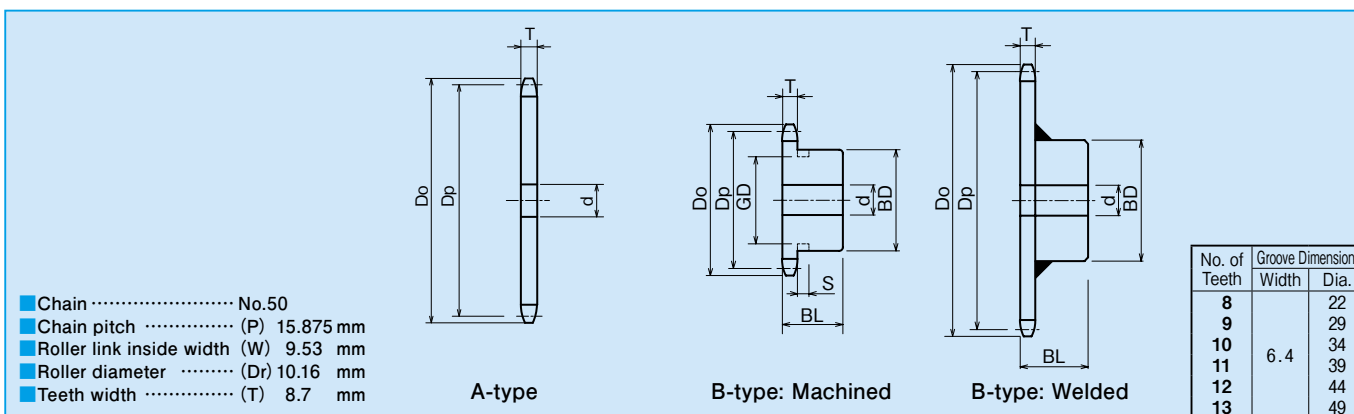

No. of Teeth	Groove Dimensions	
	Width	Dia.
8	6.4	22
9		29
10		34
11		39
12		44
13		49

○ Dimensions

[Unit: mm]

TYPE (A-type)	No. of Teeth	Outside Dia. Do	Pitch Dia. Dp	Shaft Bore Dia. d		Weight (kg)
				Drill Hole	Min.	
50A	10	58	51.37	10	11	0.14
	11	64	56.35	12	13	0.17
	12	69	61.34	12	13	0.20
	13	74	66.34	12	13	0.23
	14	79	71.34	12	13	0.27
	15	84	76.35	12	13	0.30
	16	89	81.37	14	15	0.35
	17	94	86.39	14	15	0.40
	18	100	91.42	14	15	0.45
	19	105	96.45	14	15	0.48
	20	110	101.48	14	15	0.50
	21	115	106.51	14	15	0.60
	22	120	111.55	16	17	0.66
	23	125	116.58	16	17	0.72
	24	130	121.62	16	17	0.78
	25	135	126.66	16	17	0.85
	26	140	131.70	16	17	0.90
	27	145	136.74	16	17	1.00
	28	150	141.79	16	17	1.05
	29	155	146.83	16	17	1.12
	30	161	151.87	16	17	1.20
	31	166	156.92	16	17	1.30
	32	171	161.96	16	17	1.35
	33	176	167.01	16	17	1.45
	34	181	172.05	16	17	1.55
	35	186	177.10	16	17	1.65
	36	191	182.14	19	20	1.75
	37	196	187.19	19	20	1.85
	38	201	192.24	19	20	1.95
	39	206	197.29	19	20	2.05
	40	211	202.33	19	20	2.15
	41	216	207.38	19	20	2.25
	42	221	212.43	19	20	2.40
	43	226	217.48	19	20	2.50
44	231	222.53	19	20	2.60	
45	237	227.58	19	20	2.70	
46	242	232.63	19	20	2.88	
47	247	237.68	19	20	3.01	
48	252	242.73	19	20	3.10	
49	257	247.78	19	20	3.27	
50	262	252.83	19	20	3.40	
51	267	257.88	19	20	3.55	
52	272	262.92	19	20	3.69	
53	277	267.97	19	20	3.83	
54	282	273.02	19	20	3.95	
55	287	278.08	19	20	4.13	
56	292	283.13	19	20	4.28	
57	297	288.18	19	20	4.44	
58	302	293.23	19	20	4.59	
59	307	298.28	19	20	4.75	
60	312	303.33	19	20	4.90	
64	333	323.53	20	21	5.60	
65	338	328.58	20	21	5.75	
68	353	343.74	20	21	6.32	
70	363	353.84	20	21	6.70	
72	373	363.94	20	21	7.05	
75	388	379.10	20	21	7.70	
80	414	404.36	20	21	8.70	
90	464	454.88	20	21	11.00	

TYPE (B-type)	No. of Teeth	Outside Dia. Do	Pitch Dia. Dp	Shaft Bore Dia. d			Hub Dia. BD	Hub Length BL	Weight (kg)	Construction	Material
				Drill Hole	Min.	Max.					
50B	8	48	41.48	10	11	13.5	★30	25	0.12	Machined	Carbon steel for machine structural use / Induction hardened tooth end
	9	53	46.42	10	11	18	★34	25	0.20		
	10	58	51.37	10	11	22	★40	25	0.27		
	11	64	56.35	12	13	28	★45.5	25	0.33		
	12	69	61.34	12	13	30	★50	25	0.41		
	13	74	66.34	12	13	32	★51	25	0.46		
	14	79	71.34	12	13	32	52	25	0.52		
	15	84	76.35	12	13	35	57	25	0.62		
	16	89	81.37	14	15	40	62	25	0.72		
	17	94	86.39	14	15	45	67	25	0.83		
	18	100	91.42	14	15	48	72	28	1.00		
	19	105	96.45	14	15	48	73	28	1.10		
	20	110	101.48	14	15	48	73	28	1.20		
	21	115	106.51	14	15	48	73	28	1.20		
	22	120	111.55	16	17	48	73	28	1.30		
	23	125	116.58	16	17	48	73	28	1.30		
	24	130	121.62	16	17	48	73	28	1.40		
	25	135	126.66	16	17	48	73	28	1.50		
	26	140	131.70	16	17	48	73	28	1.50		
	27	145	136.74	16	17	48	73	28	1.50		
	28	150	141.79	16	17	48	73	28	1.60		
	29	155	146.83	16	17	48	73	28	1.70		
	30	161	151.87	16	17	48	73	28	1.80		
	31	166	156.92	16	17	48	73	28	1.85		
	32	171	161.96	16	17	48	73	28	1.90		
	33	176	167.01	16	17	48	73	28	2.00		
	34	181	172.05	16	17	48	73	28	2.10		
	35	186	177.10	16	17	48	73	28	2.20		
	36	191	182.14	19	20	55	83	35	2.85		
	37	196	187.19	19	20	55	83	35	2.95		
	38	201	192.24	19	20	55	83	35	3.05		
	39	206	197.29	19	20	55	83	35	3.15		
	40	211	202.33	19	20	55	83	35	3.25		
	41	216	207.38	19	20	55	83	35	3.40		
42	221	212.43	19	20	55	83	35	3.50			
43	226	217.48	19	20	55	83	35	3.60			
44	231	222.53	19	20	55	83	35	3.70			
45	237	227.58	19	20	55	83	35	3.85			
46	242	232.63	19	20	55	83	35	3.96			
47	247	237.68	19	20	55	83	35	4.09			
48	252	242.73	19	20	55	83	35	4.20			
49	257	247.78	19	20	55	83	35	4.35			
50	262	252.83	19	20	55	83	35	4.50			
51	267	257.88	19	20	55	83	35	4.62			
52	272	262.92	19	20	55	83	35	4.76			
53	277	267.97	19	20	55	83	35	4.91			
54	282	273.02	19	20	55	83	35	5.05			
55	287	278.08	19	20	55	83	35	5.20			
56	292	283.13	19	20	55	83	35	5.36			
57	297	288.18	19	20	55	83	35	5.51			
58	302	293.23	19	20	55	83	35	5.67			
59	307	298.28	19	20	55	83	35	6.00			
60	312	303.33	19	20	55	83	35	7.40			
64	333	323.53	20	21	63	93	40	7.94			
65	338	328.58	20	21	63	93	40	8.30			
68	353	343.74	20	21	63	93	40	9.35			
70	363	353.84	20	21	63	93	40	10.50			
75	388	379.10	20	21	66	98	45	12.00			
80	414	404.36	20	21	66	98	45	13.20			
85	439	429.62	20	21	66	98	45				
90	464	454.88	20	21	66	98	45				

NOTES: - Material of A-type is all common steel.  
 - Shaft bore, key, tap, and the like will be processed to meet your request.  
 - Sprockets other than those listed above are also manufactured. Contact us.  
 - Sprockets marked with star ★ are provided with groove on hub perimeter. See Groove Dimensions Table.

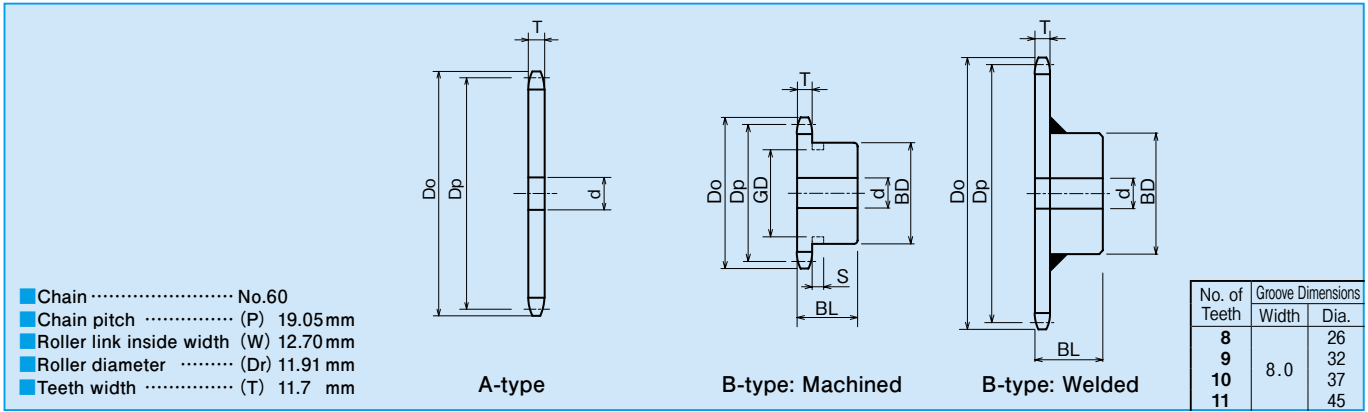

○ Dimensions

[Unit: mm]

TYPE (A-type)	No. of Teeth	Outside Dia. Do	Pitch Dia. Dp	Shaft Bore Dia. d		Weight (kg)
				Drill Hole	Min.	
60A	10	70	61.65	14	15	0.27
	11	76	67.62	14	15	0.30
	12	83	73.60	14	15	0.38
	13	89	79.60	14	15	0.45
	14	95	85.61	16	17	0.50
	15	101	91.62	16	17	0.60
	16	107	97.65	16	17	0.65
	17	113	103.67	16	17	0.75
	18	119	109.71	16	17	0.84
	19	126	115.74	16	17	0.93
	20	132	121.78	16	17	1.05
	21	138	127.82	16	17	1.15
	22	144	133.86	16	17	1.25
	23	150	139.90	16	17	1.40
	24	156	145.95	18	19	1.50
	25	162	151.99	18	19	1.62
	26	168	158.04	18	19	1.78
	27	174	164.09	18	19	1.90
	28	180	170.14	18	19	2.05
	29	187	176.20	18	19	2.20
	30	193	182.25	18	19	2.35
	31	199	188.30	20	21	2.50
	32	205	194.35	20	21	2.68
	33	211	200.41	20	21	2.85
	34	217	206.46	20	21	3.02
	35	223	212.52	20	21	3.25
	36	229	218.57	20	21	3.40
	37	235	224.63	20	21	3.60
	38	241	230.69	20	21	3.80
	39	247	236.74	20	21	4.00
40	253	242.80	20	21	4.20	
41	260	248.86	20	21	4.45	
42	266	254.92	20	21	4.63	
43	272	260.98	20	21	4.85	
44	278	267.03	20	21	5.10	
45	284	273.09	20	21	5.30	
46	290	279.15	20	21	5.59	
47	296	285.21	20	21	5.83	
48	302	291.27	20	21	6.10	
49	308	297.33	20	21	6.34	
50	314	303.39	20	21	6.60	
51	320	309.45	20	21	6.87	
52	326	315.51	20	21	7.15	
53	332	321.57	20	21	7.44	
54	338	327.63	20	21	7.70	
55	345	333.69	20	21	8.00	
57	357	345.81	20	21	8.59	
58	363	351.87	20	21	8.90	
60	375	363.99	20	21	9.50	
65	405	394.30	26	27	11.20	
70	436	424.61	26	27	13.00	
72	448	436.73	26	27	13.70	
75	466	454.92	26	27	14.90	
80	496	485.23	26	27	16.90	
90	557	545.85	26	27	21.40	

TYPE (B-type)	No. of Teeth	Outside Dia. Do	Pitch Dia. Dp	Shaft Bore Dia. d			Hub Dia. BD	Hub Length BL	Weight (kg)	Construction	Material
				Drill Hole	Min.	Max.					
60B	8	58	49.78	12	13	20	★34	32	0.30	Machined	Carbon steel for machine structural use / Induction hardened tooth end
	9	64	55.70	12	13	25	★43	32	0.40		
	10	70	61.65	14	15	30	★49	32	0.49		
	11	76	67.62	14	15	32	★51	32	0.60		
	12	83	73.60	14	15	32	51	32	0.69		
	13	89	79.60	14	15	35	57	32	0.81		
	14	95	85.61	16	17	40	62	32	0.96		
	15	101	91.62	16	17	45	68	32	1.10		
	16	107	97.65	16	17	48	73	32	1.30		
	17	113	103.67	16	17	48	73	32	1.40		
	18	119	109.71	16	17	55	83	40	2.00		
	19	126	115.74	16	17	55	83	40	2.10		
	20	132	121.78	16	17	55	83	40	2.20		
	21	138	127.82	16	17	55	83	40	2.30		
	22	144	133.86	16	17	55	83	40	2.50		
	23	150	139.90	16	17	55	83	40	2.50		
	24	156	145.95	18	19	55	83	40	2.60		
	25	162	151.99	18	19	55	83	40	2.70		
	26	168	158.04	18	19	55	83	40	2.90		
	27	174	164.09	18	19	55	83	40	3.00		
	28	180	170.14	18	19	55	83	40	3.10		
	29	187	176.20	18	19	55	83	40	3.30		
	30	193	182.25	18	19	55	83	40	3.40		
	31	199	188.30	20	21	55	83	40	3.64		
	32	205	194.35	20	21	55	83	40	3.80		
	33	211	200.41	20	21	55	83	40	4.00		
	34	217	206.46	20	21	55	83	40	4.15		
	35	223	212.52	20	21	55	83	40	4.33		
	36	229	218.57	20	21	55	83	40	4.52		
	37	235	224.63	20	21	55	83	40	4.70		
38	241	230.69	20	21	55	83	40	4.90			
39	247	236.74	20	21	55	83	40	5.10			
40	253	242.80	20	21	55	83	40	5.30			
41	260	248.86	20	21	63	93	45	6.00			
42	266	254.92	20	21	63	93	45	6.40			
43	272	260.98	20	21	63	93	45	6.60			
44	278	267.03	20	21	63	93	45	6.88			
45	284	273.09	20	21	63	93	45	7.10			
46	290	279.15	20	21	63	93	45	7.28			
47	296	285.21	20	21	63	93	45	7.53			
48	302	291.27	20	21	63	93	45	7.85			
49	308	297.33	20	21	63	93	45	8.04			
50	314	303.39	20	21	63	93	45	8.40			
51	320	309.45	20	21	63	93	45	8.57			
52	326	315.51	20	21	63	93	45	8.84			
54	338	327.63	20	21	63	93	45	9.50			
55	345	333.69	20	21	63	93	45	9.69			
56	351	339.75	20	21	63	93	45	9.99			
58	363	351.87	20	21	63	93	45	10.59			
60	375	363.99	20	21	63	93	45	11.30			
64	399	388.24	26	27	63	93	45	12.50			
65	405	394.30	26	27	75	107	45	13.50			
70	436	424.61	26	27	75	107	45	15.30			
75	466	454.92	26	27	75	107	45	17.20			
80	496	485.23	26	27	80	117	50	20.00			
85	527	515.54	26	27	80	117	50	22.30			
90	557	545.85	26	27	80	117	50	24.60			

- NOTES: - Material of A-type is all common steel.  
 - Shaft bore, key, tap, and the like will be processed to meet your request.  
 - Sprockets other than those listed above are also manufactured. Contact us.  
 - Sprockets marked with star ★ are provided with groove on hub perimeter. See Groove Dimensions Table.



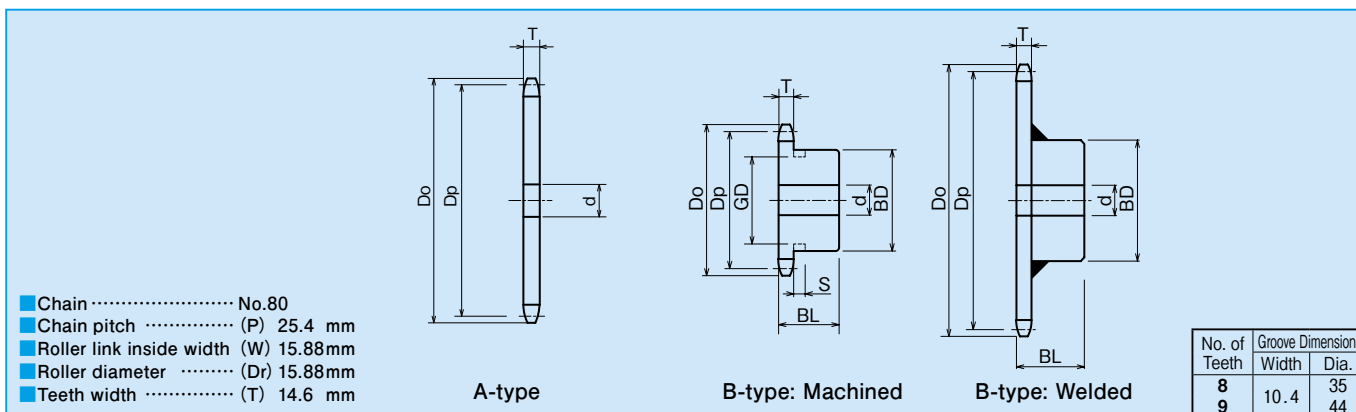

○ Dimensions

[Unit: mm]

TYPE (A-type)	No. of Teeth	Outside Dia. Do	Pitch Dia. Dp	Shaft Bore Dia. d		Weight (kg)
				Drill Hole	Min.	
80A	10	93	82.19	15	16	0.60
	11	102	90.16	15	16	0.73
	12	110	98.14	15	16	0.83
	13	118	106.14	16	17	1.00
	14	127	114.15	16	17	1.16
	15	135	122.17	20	21	1.30
	16	143	130.20	20	21	1.50
	17	151	138.23	20	21	1.70
	18	159	146.27	20	21	1.90
	19	167	154.32	20	21	2.10
	20	176	162.37	20	21	2.35
	21	184	170.42	20	21	2.57
	22	192	178.48	26	27	2.82
	23	200	186.54	26	27	3.10
	24	208	194.60	26	27	3.35
	25	216	202.66	26	27	3.65
	26	224	210.72	26	27	3.95
	27	233	218.79	26	27	4.25
	28	241	226.86	26	27	4.60
	29	249	234.93	26	27	4.93
	30	257	243.00	26	27	5.30
	31	265	251.07	26	27	5.63
	32	273	259.14	26	27	6.00
	33	281	267.21	26	27	6.40
	34	289	275.29	26	27	6.80
	35	297	283.36	26	27	7.20
	36	306	291.43	26	27	7.60
	37	314	299.51	26	27	8.00
	38	322	307.58	26	27	8.50
	39	330	315.66	26	27	8.90
	40	338	323.74	26	27	9.40
	41	346	331.81	26	27	9.90
	42	354	339.89	26	27	10.30
	43	362	347.97	26	27	10.80
	44	370	356.04	26	27	11.40
	45	378	364.12	26	27	11.90
	46	387	372.20	26	27	12.40
	47	395	380.28	26	27	12.95
	48	403	388.36	26	27	13.50
	49	411	396.44	26	27	14.08
50	419	404.52	26	27	14.70	
52	435	420.68	26	27	15.86	
53	443	428.76	26	27	16.48	
54	451	436.84	26	27	17.10	
55	459	444.92	26	27	17.75	
56	468	453.00	26	27	18.40	
57	476	461.08	26	27	19.07	
58	484	469.16	26	27	19.75	
60	500	485.33	26	27	21.10	
64	532	517.65	26	27	24.05	
65	540	525.73	26	27	24.80	
66	548	533.82	26	27	25.58	
70	581	566.15	26	27	28.80	
75	621	606.56	26	27	33.10	
80	662	646.97	26	27	37.60	
90	743	727.80	26	27	47.60	

TYPE (B-type)	No. of Teeth	Outside Dia. Do	Pitch Dia. Dp	Shaft Bore Dia. d			Hub Dia. BD	Hub Length BL	Weight (kg)	Construction	Material
				Drill Hole	Min.	Max.					
80B	8	77	66.37	14	15	22	★49	40	0.70	Machined	Carbon steel for machine structural use / Induction hardened tooth end
	9	85	74.27	14	15	35	★58	40	0.87		
	10	93	82.19	15	16	32	52	40	1.02		
	11	102	90.16	15	16	38	60	40	1.25		
	12	110	98.14	15	16	45	67	40	1.60		
	13	118	106.14	16	17	51	77	40	1.90		
	14	127	114.15	16	17	51	77	40	2.15		
	15	135	122.17	20	21	63	93	40	2.30		
	16	143	130.20	20	21	63	93	40	2.50		
	17	151	138.23	20	21	63	93	40	2.95		
	18	159	146.27	20	21	63	93	40	3.15		
	19	167	154.32	20	21	63	93	40	3.40		
	20	176	162.37	20	21	63	93	40	3.60		
	21	184	170.42	20	21	63	93	40	3.85		
	22	192	178.48	26	27	75	107	45	5.00		
	23	200	186.54	26	27	75	107	45	5.23		
	24	208	194.60	26	27	75	107	45	5.50		
	25	216	202.66	26	27	75	107	45	5.80		
	26	224	210.72	26	27	75	107	45	6.10		
	27	233	218.79	26	27	75	107	45	6.40		
	28	241	226.86	26	27	75	107	45	6.75		
	29	249	234.93	26	27	75	107	45	7.10		
	30	257	243.00	26	27	75	107	45	7.40		
	31	265	251.07	26	27	75	107	45	7.80		
	32	273	259.14	26	27	75	107	45	8.15		
	33	281	267.21	26	27	75	107	45	8.50		
	34	289	275.29	26	27	75	107	45	8.90		
	35	297	283.36	26	27	75	107	45	9.30		
	36	306	291.43	26	27	80	117	50	10.60		
	37	314	299.51	26	27	80	117	50	11.00		
	38	322	307.58	26	27	80	117	50	11.40		
	39	330	315.66	26	27	80	117	50	11.90		
	40	338	323.74	26	27	80	117	50	12.40		
	41	346	331.81	26	27	80	117	50	12.80		
	42	354	339.89	26	27	80	117	50	13.30		
	43	362	347.97	26	27	80	117	50	13.80		
	44	370	356.04	26	27	80	117	50	14.30		
	45	378	364.12	26	27	80	117	50	14.90		
	46	387	372.20	26	27	80	117	50	15.30		
	47	395	380.28	26	27	80	117	50	15.70		
48	403	388.36	26	27	80	117	50	15.80			
50	419	404.52	26	27	80	117	50	17.65			
52	435	420.68	26	27	80	117	50	18.70			
53	443	428.76	26	27	80	117	50	19.30			
54	451	436.84	26	27	80	117	50	20.00			
55	459	444.92	26	27	80	117	50	20.60			
56	468	453.00	26	27	80	117	50	21.30			
58	484	469.16	26	27	80	117	50	22.55			
59	492	477.24	26	27	80	117	50	22.50			
60	500	485.33	26	27	80	117	50	23.10			
65	540	525.73	26	27	89	127	63	29.40			
70	581	566.15	26	27	89	127	63	32.10			
75	621	606.56	26	27	89	127	63	36.20			
80	662	646.97	26	27	95	137	71	42.90			
90	743	727.80	26	27	95	137	71	53.00			

NOTES: - Material of A-type is all common steel.

- Shaft bore, key, tap, and the like will be processed to meet your request.
- Sprockets other than those listed above are also manufactured. Contact us.
- Sprockets marked with star ★ are provided with groove on hub perimeter. See Groove Dimensions Table.



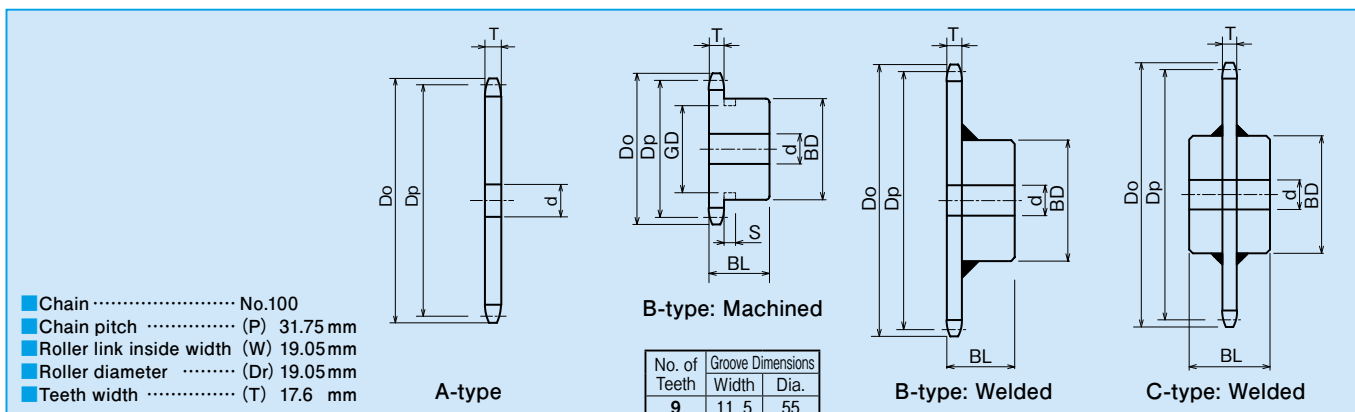

No. of Teeth	Groove Dimensions	
	Width	Dia.
9	11.5	55

○ Dimensions

[Unit: mm]

TYPE (A-type)	No. of Teeth	Outside Dia. Do	Pitch Dia. Dp	Shaft Bore Dia. d		Weight (kg)
				Drill Hole	Min.	
100A	10	117	102.74	20	21	1.10
	11	127	112.70	20	21	1.30
	12	138	122.67	20	21	1.60
	13	148	132.67	20	21	1.90
	14	158	142.68	20	21	2.15
	15	168	152.71	20	21	2.50
	16	179	162.74	20	21	2.83
	17	189	172.79	20	21	3.20
	18	199	182.84	20	21	3.60
	19	209	192.90	20	21	4.00
	20	220	202.96	20	21	4.40
	21	230	213.03	20	21	4.90
	22	240	223.10	26	27	5.35
	23	250	233.17	26	27	5.80
	24	260	243.25	26	27	6.40
	25	270	253.32	26	27	6.90
	26	281	263.40	26	27	7.50
	27	291	273.49	26	27	8.10
	28	301	283.57	26	27	8.70
	29	311	293.66	26	27	9.30
	30	321	303.75	26	27	10.00
	31	331	313.83	26	27	10.63
	32	341	323.92	26	27	11.35
	33	352	334.01	26	27	12.00
	34	362	344.11	26	27	12.80
	35	372	354.20	26	27	13.50
	36	382	364.29	26	27	14.40
	37	392	374.38	26	27	15.10
	38	402	384.48	26	27	16.00
	39	412	394.57	26	27	16.80
	40	422	404.67	26	27	17.70
	41	433	414.77	26	27	18.60
	42	443	424.86	26	27	19.50
	43	453	434.96	26	27	20.50
44	463	445.06	26	27	21.45	
45	473	455.16	26	27	22.40	
46	483	465.25	26	27	23.40	
48	503	485.45	26	27	25.50	
50	524	505.65	26	27	27.70	
52	544	525.85	26	27	29.90	
54	564	546.05	26	27	32.30	
60	625	606.66	26	27	39.90	
65	675	657.17	26	27	46.80	
70	726	707.68	26	27	54.30	
75	777	758.20	30	31	62.30	
80	827	808.71	30	31	70.90	
90	928	909.75	30	31	89.58	

TYPE (B-type, C-type)	No. of Teeth	Outside Dia. Do	Pitch Dia. Dp	Shaft Bore Dia. d			Hub Dia. BD	Hub Length BL	Weight (kg)	Construction	Material		
				Drill Hole	Min.	Max.							
100B	9	106	92.84	20	21	40	★70	50	1.6	Machined	Carbon steel for machine structural use / Induction hardened tooth end		
	10	117	102.74	20	21	45	65	50	1.9				
	11	127	112.70	20	21	51	75	50	2.3				
	12	138	122.67	20	21	57	86	50	2.9				
	13	148	132.67	20	21	63	94	50	3.1				
	14	158	142.68	20	21	66	98	50	3.6				
	15	168	152.71	20	21	66	98	50	4.2				
	16	179	162.74	20	21	66	98	50	4.6				
	17	189	172.79	20	21	75	107	50	5.3				
	18	199	182.84	20	21	75	107	50	5.7				
	19	209	192.90	20	21	75	107	50	6.1				
	20	220	202.96	20	21	75	107	50	6.5				
	21	230	213.03	20	21	75	107	50	7.0				
	22	240	223.10	26	27	80	117	56	7.9			Machined	
	23	250	233.17	26	27	80	117	56	8.5				
	24	260	243.25	26	27	80	117	56	8.8				
	25	270	253.32	26	27	80	117	56	9.3				
	26	281	263.40	26	27	80	117	56	9.8				
	27	291	273.49	26	27	80	117	56	10.3				
	28	301	283.57	26	27	80	117	56	10.9	Welded	Common steel		
	29	311	293.66	26	27	80	117	56	11.5				
	30	321	303.75	26	27	80	117	56	12.1				
	32	341	323.92	26	27	80	117	56	14.5				
	33	352	334.01	26	27	80	117	56	16.1				
	34	362	344.11	26	27	80	117	56	16.6				
	35	372	354.20	26	27	89	127	63	17.5				
	36	382	364.29	26	27	89	127	63	18.0				
	37	392	374.38	26	27	89	127	63	18.9				
	38	402	384.48	26	27	89	127	63	19.5				
	39	412	394.57	26	27	89	127	63	20.0				
	40	422	404.67	26	27	89	127	63	20.4				
	41	433	414.77	26	27	89	127	63	21.5				
	42	443	424.86	26	27	89	127	63	22.6				
	45	473	455.16	26	27	89	127	63	24.7				
47	493	475.35	26	27	89	127	63	26.7					
48	503	485.45	26	27	89	127	63	27.5					
50	524	505.65	26	27	89	127	63	30.0					
54	564	546.05	26	27	103	147	80	37.4					
55	574	556.15	26	27	103	147	80	41.6					
60	625	606.66	26	27	103	147	80	44.3					
65	675	657.17	26	27	103	147	80	54.5					
70	726	707.68	26	27	103	147	100	64.7					
75	777	758.20	30	31	103	147	100	72.7					

NOTES: - Material of A-type is all common steel.  
 - Shaft bore, key, tap, and the like will be processed to meet your request.  
 - Sprockets other than those listed above are also manufactured. Contact us.  
 - Sprockets marked with star ★ are provided with groove on hub perimeter. See Groove Dimensions Table.

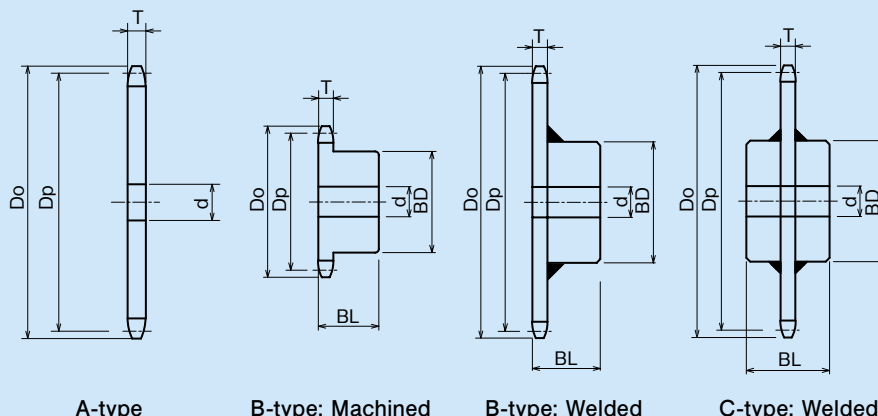

- Chain ..... No.120
- Chain pitch ..... (P) 38.10mm
- Roller link inside width (W) 25.40mm
- Roller diameter ..... (Dr) 22.23mm
- Teeth width ..... (T) 23.5 mm

○ Dimensions

[Unit: mm]

TYPE (A-type)	No. of Teeth	Outside Dia. Do	Pitch Dia. Dp	Shaft Bore Dia. d		Weight (kg)
				Drill Hole	Min.	
	10	140	123.29	23	24	2.16
	11	153	135.24	25	26	2.60
	12	165	147.21	25	26	3.10
	13	177	159.20	25	26	3.60
	14	190	171.22	25	26	4.20
	15	202	183.25	25	26	4.80
	16	214	195.29	25	26	5.50
	17	227	207.35	25	26	6.20
	18	239	219.41	25	26	6.95
	19	251	231.48	25	26	7.70
	20	263	243.55	25	26	8.55
	21	276	255.63	25	26	9.40
	22	288	267.72	26	27	10.30
	23	300	279.80	26	27	11.30
	24	312	291.90	26	27	12.30
120A	25	324	303.99	26	27	13.30
	26	337	316.09	26	27	14.40
	27	349	328.19	26	27	15.50
	28	361	340.29	26	27	16.70
	29	373	352.39	26	27	17.80
	30	385	364.50	26	27	19.20
	31	398	376.60	30	31	20.40
	32	410	388.71	30	31	21.80
	33	422	400.82	30	31	23.20
	34	434	412.93	30	31	24.60
	35	446	425.04	30	31	26.10
	36	458	437.15	30	31	27.60
	38	483	461.38	30	31	30.80
	40	507	485.60	30	31	34.10
	42	531	509.83	30	31	37.60
		44	556	534.07	30	31
	45	568	546.19	30	31	43.10
	46	580	558.30	30	31	45.10
	48	604	582.54	30	31	49.00
	50	628	606.78	30	31	53.30
	54	677	655.26	30	31	62.10
	60	750	727.99	30	31	76.70
	70	871	849.22	30	31	104.30
	75	932	909.84	30	31	119.80
	80	993	970.46	30	31	136.30

TYPE (B-type, C-type)	No. of Teeth	Outside Dia. Do	Pitch Dia. Dp	Shaft Bore Dia. d			Hub Dia. BD	Hub Length BL	Weight (kg)	Construction	Material
				Drill Hole	Min.	Max.					
120B	10	140	123.29	23	24	51	78	56	3.20	Machined	Carbon steel for machine structural use / Induct on hardened both end
	11	153	135.24	25	26	60	91	56	4.00		
	12	165	147.21	25	26	66	98	56	4.80		
	13	177	159.20	25	26	66	98	56	5.30		
	14	190	171.22	25	26	75	107	56	6.30		
	15	202	183.25	25	26	80	117	63	7.80		
	16	214	195.29	25	26	80	117	63	8.40		
	17	227	207.35	25	26	80	117	63	9.10		
	18	239	219.41	25	26	80	117	63	9.90		
	19	251	231.48	25	26	80	117	63	10.70		
	20	263	243.55	25	26	89	127	63	12.10		
	21	276	255.63	25	26	89	127	63	13.00		
	22	288	267.72	26	27	89	127	63	13.40		
	23	300	279.80	26	27	89	127	63	14.50		
	24	312	291.90	26	27	89	127	63	15.20		
	25	324	303.99	26	27	89	127	63	16.20		
	26	337	316.09	26	27	89	127	63	17.20		
	28	361	340.29	26	27	95	137	71	20.90		
	30	385	364.50	26	27	95	137	71	23.20		
	32	410	388.71	30	31	95	137	71	25.70		
	33	422	400.82	30	31	95	137	71	28.40		
	34	434	412.93	30	31	95	137	71	29.00		
	35	446	425.04	30	31	95	137	71	29.70		
	36	458	437.15	30	31	95	137	71	32.00		
38	483	461.38	30	31	95	137	71	35.00			
40	507	485.60	30	31	103	147	80	38.20			
42	531	509.83	30	31	103	147	80	42.00			
45	568	546.19	30	31	103	147	80	47.60			
48	604	582.54	30	31	103	147	80	53.00			
50	628	606.78	30	31	103	147	80	58.00			
120C	54	677	655.26	30	31	103	147	100	65.20	Welded	Common steel
	60	750	727.99	30	31	103	167	100	78.00		

NOTES: - Material of A-type is all common steel.

- Shaft bore, key, tap, and the like will be processed to meet your request.
- Sprockets other than those listed above are also manufactured. Contact us.

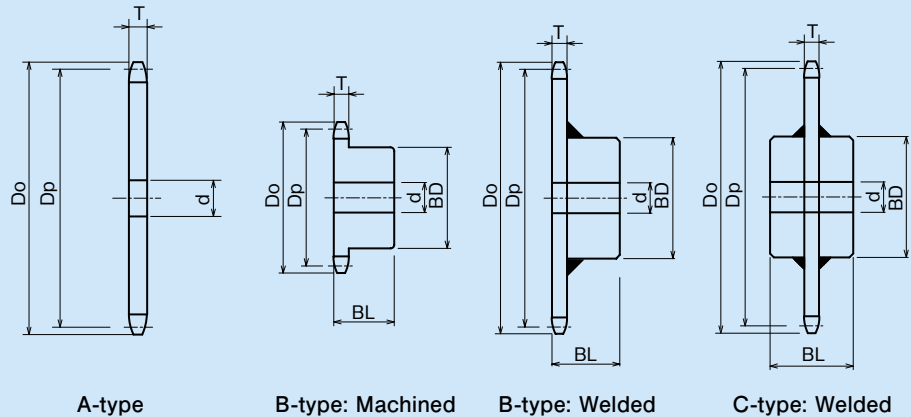

- Chain ..... No.140
- Chain pitch ..... (P) 44.45mm
- Roller link inside width (W) 25.22mm
- Roller diameter ..... (Dr) 25.40mm
- Teeth width ..... (T) 23.5 mm

○ Dimensions

[Unit: mm]

TYPE (A-type)	No. of Teeth	Outside Dia. Do	Pitch Dia. Dp	Shaft Bore Dia. d		Weight (kg)
				Drill Hole	Min.	
140A	10	163	143.84	26	27	2.90
	11	178	157.78	26	27	3.60
	12	193	171.74	26	27	4.20
	13	207	185.74	26	27	4.90
	14	221	199.76	26	27	5.70
	15	236	213.79	26	27	6.60
	16	250	227.84	26	27	7.50
	17	264	241.91	26	27	8.40
	18	279	255.98	26	27	9.40
	19	293	270.06	26	27	10.50
	20	307	284.15	26	27	11.60
	21	322	298.24	26	27	12.80
	22	336	312.34	30	31	14.10
	23	350	326.44	30	31	15.30
	24	364	340.54	30	31	16.70
	25	379	354.65	30	31	18.10
	26	393	368.77	30	31	19.60
	28	421	397.00	30	31	23.00
	30	450	425.24	30	31	26.00
	32	478	453.49	30	31	29.70
	35	521	495.88	30	31	35.60
	38	563	538.27	30	31	41.90
	40	591	566.54	30	31	46.40
	42	620	594.81	30	31	51.10
	45	662	637.22	30	31	58.80
	48	705	679.63	30	31	66.90
	50	733	707.91	30	31	72.50
	54	790	764.47	35	36	84.60
	60	875	849.32	35	36	104.00

TYPE (B-type, C-type)	No. of Teeth	Outside Dia. Do	Pitch Dia. Dp	Shaft Bore Dia. d			Hub Dia. BD	Hub Length BL	Weight (kg)	Construction	Material
				Drill Hole	Min.	Max.					
140B	10	163	143.84	26	27	66	98	56	4.90	Machined	Carbon steel for machine structural use
	11	178	157.78	26	27	70	106	56	5.50		
	12	193	171.74	26	27	80	117	56	6.60		
	13	207	185.74	26	27	80	117	63	7.90		
	14	221	199.76	26	27	89	127	63	9.30		
	15	236	213.79	26	27	89	127	63	10.10		
	16	250	227.84	26	27	89	127	63	11.00		
	17	264	241.91	26	27	89	127	63	12.00		
	18	279	255.98	26	27	89	127	63	13.00		
	19	293	270.06	26	27	95	137	71	15.60		
	20	307	284.15	26	27	95	137	71	16.70		
	21	322	298.24	26	27	95	137	71	17.90		
	22	336	312.34	30	31	95	137	71	18.40		
	23	350	326.44	30	31	95	137	71	20.10		
	24	364	340.54	30	31	95	137	71	20.90		
	25	379	354.65	30	31	103	147	80	24.10		
	26	393	368.77	30	31	103	147	80	25.50		
	27	407	382.88	30	31	103	147	80	28.20		
	28	421	397.00	30	31	103	147	80	30.10		
	30	450	425.24	30	31	103	147	80	31.50		
32	478	453.49	30	31	103	147	80	36.00			
35	521	495.88	30	31	110	157	90	42.90			
38	563	538.27	30	31	110	157	90	47.40			
40	591	566.54	30	31	110	157	90	51.00			
42	620	594.81	30	31	110	157	90	53.10			
44	650	623.12	30	31	110	157	90	58.80			
48	705	679.63	30	31	118	167	100	68.00			
50	733	707.91	30	31	118	167	100	72.50			
54	790	764.47	35	36	118	167	100	84.60			
60	875	849.32	35	36	118	167	112	104.00			

NOTES: - Material of A-type is all common steel.  
 - Shaft bore, key, tap, and the like will be processed to meet your request.  
 - Sprockets other than those listed above are also manufactured. Contact us.

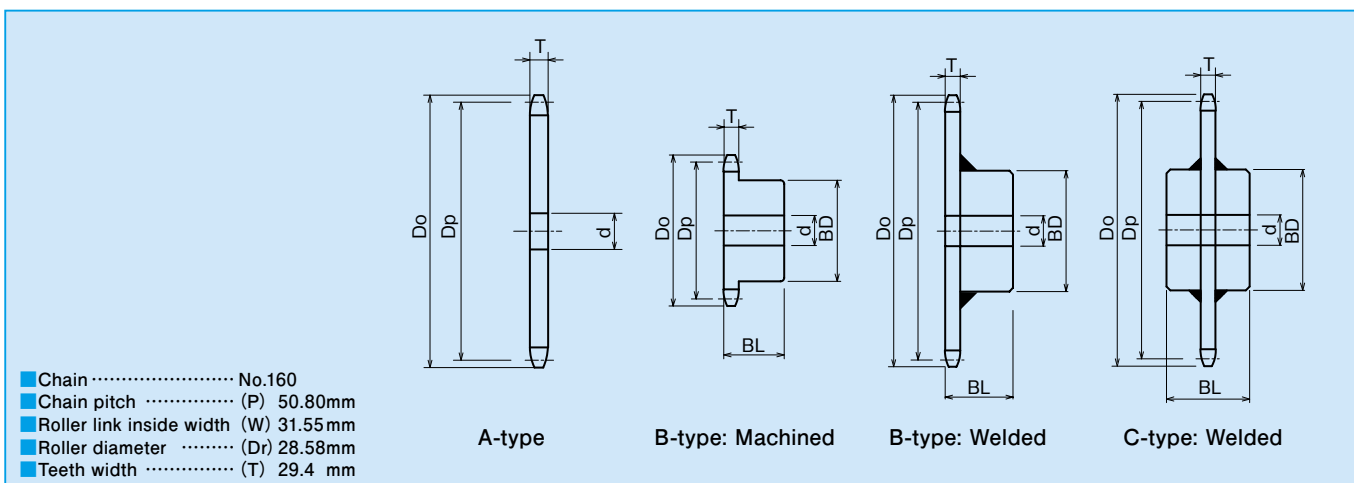

○ Dimensions

[Unit: mm]

TYPE (A-type)	No. of Teeth	Outside Dia. Do	Pitch Dia. Dp	Shaft Bore Dia. d		Weight (kg)
				Drill Hole	Min.	
160A	10	187	164.39	26	27	4.85
	11	204	180.31	26	27	5.85
	12	220	196.28	26	27	6.90
	13	237	212.27	26	27	8.10
	14	253	228.30	26	27	9.40
	15	269	244.33	30	31	10.80
	16	286	260.39	30	31	12.25
	17	302	276.46	30	31	13.80
	18	319	292.55	30	31	15.50
	19	335	308.64	30	31	17.20
	20	351	324.74	30	31	19.00
	21	368	340.84	30	31	21.00
	22	384	356.96	35	36	23.00
	23	400	373.07	35	36	25.10
	24	416	389.19	35	36	27.40
	25	433	405.32	35	36	29.70
	26	449	421.45	35	36	32.10
	28	481	453.72	35	36	37.20
	30	514	485.99	35	36	42.70
	32	546	518.28	35	36	48.70
	35	595	566.71	35	36	58.10
	38	644	615.17	35	36	68.50
	40	676	647.47	35	36	75.10
	45	757	728.25	35	36	96.00
48	806	776.72	35	36	109.00	
50	838	809.04	35	36	118.50	
54	903	873.68	35	36	138.20	
60	1,000	970.65	35	36	170.00	

TYPE (B-type, C-type)	No. of Teeth	Outside Dia. Do	Pitch Dia. Dp	Shaft Bore Dia. d			Hub Dia. BD	Hub Length BL	Weight (kg)	Construction	Material
				Drill Hole	Min.	Max.					
160B	10	187	164.39	26	27	70	105	63	6.80	Machined	Carbon steel for machine structural use
	11	204	180.31	26	27	80	117	63	8.30		
	12	220	196.28	26	27	89	127	63	9.90		
	13	237	212.27	26	27	95	137	71	12.50		
	14	253	228.30	26	27	95	137	71	13.80		
	15	269	244.33	30	31	95	137	71	15.20		
	16	286	260.39	30	31	103	147	71	17.40		
	17	302	276.46	30	31	103	147	71	18.90		
	18	319	292.55	30	31	103	147	71	20.60		
	19	335	308.64	30	31	103	147	71	22.30		
	20	351	324.74	30	31	103	147	71	24.20		
	21	368	340.84	30	31	103	147	71	26.10		
	22	384	356.96	35	36	118	167	80	30.20		
	24	416	389.19	35	36	118	167	80	34.40		
	25	433	405.32	35	36	118	167	80	36.60		
	26	449	421.45	35	36	118	167	80	38.90		
	30	514	485.99	35	36	118	167	100	52.30		
	32	546	518.28	35	36	118	167	100	59.00		
	35	595	566.71	35	36	118	167	100	66.90		
	40	676	647.47	35	36	118	167	112	88.00		
160C	45	757	728.25	35	36	132	187	125	115.00	Welded	Common steel
	48	806	776.72	35	36	132	187	125	128.00		
	50	838	809.04	35	36	132	187	125	138.70		
	54	903	873.68	35	36	132	187	125	158.40		
	60	1,000	970.65	35	36	132	187	125	190.80		

NOTES: - Material of A-type is all common steel.

- Shaft bore, key, tap, and the like will be processed to meet your request.
- Sprockets other than those listed above are also manufactured. Contact us.

## ●B-Type for S-Roller

Sprocket with odd number of teeth where chain roller engages with the original tooth in two rotation features longer wear life. A number of teeth where chain engages every other tooth is referred to as a number of working teeth.

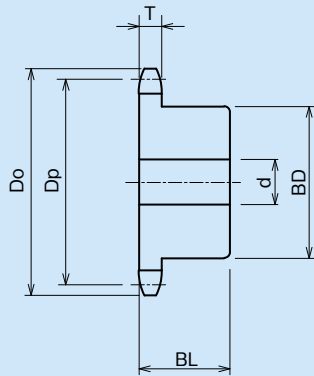

- KCM 2040**
- Chain pitch ..... (P) 25.4 mm
  - Roller link inside width (W) 7.95 mm
  - Roller diameter ..... (Dr) 7.92 mm
  - Teeth width ..... (T) 7.2 mm

TYPE (B-type)	No. of Actual Teeth	No. of Working Teeth	Outside Dia. Do	Pitch Dia. Dp	Shaft Bore Dia. d			Hub Dia. BD	Hub Length BL	Weight (kg)	Material
					Drill Hole	Min.	Max.				
2040B	13	6½	59	54.66	12	13	20	35	22	0.20	Carbon steel for machine structural use / Induction hardened tooth end
	15	7½	67	62.45	12	13	25	43	22	0.30	
	17	8½	76	70.31	13	14	32	52	22	0.42	
	19	9½	84	78.23	14	15	38	60	25	0.61	
	21	10½	92	86.17	14	15	46	69	25	0.82	
	23	11½	100	94.15	14	15	51	77	25	0.98	
25	12½	108	102.14	14	15	42	63	25	0.83		

- KCM 2050**
- Chain pitch ..... (P) 31.75 mm
  - Roller link inside width (W) 9.53 mm
  - Roller diameter ..... (Dr) 10.16 mm
  - Teeth width ..... (T) 8.7 mm

TYPE (B-type)	No. of Actual Teeth	No. of Working Teeth	Outside Dia. Do	Pitch Dia. Dp	Shaft Bore Dia. d			Hub Dia. BD	Hub Length BL	Weight (kg)	Material
					Drill Hole	Min.	Max.				
2050B	13	6½	74	68.32	12	13	25	44	25	0.38	Carbon steel for machine structural use / Induction hardened tooth end
	15	7½	84	78.06	12	13	32	54	25	0.55	
	17	8½	94	87.89	14	15	45	65	25	0.76	
	19	9½	105	97.78	14	15	48	73	28	1.06	
	21	10½	115	107.72	14	15	48	73	28	1.16	
	23	11½	125	117.68	16	17	48	73	28	1.27	
25	12½	135	127.67	16	17	48	73	28	1.40		

- KCM 2060**
- Chain pitch ..... (P) 38.10 mm
  - Roller link inside width (W) 12.70 mm
  - Roller diameter ..... (Dr) 11.91 mm
  - Teeth width ..... (T) 11.7 mm

TYPE (B-type)	No. of Actual Teeth	No. of Working Teeth	Outside Dia. Do	Pitch Dia. Dp	Shaft Bore Dia. d			Hub Dia. BD	Hub Length BL	Weight (kg)	Material
					Drill Hole	Min.	Max.				
2060B	13	6½	88	81.98	14	15	32	53	32	0.73	Carbon steel for machine structural use / Induction hardened tooth end
	15	7½	101	93.67	16	17	45	66	32	1.05	
	17	8½	113	105.47	16	17	48	73	32	1.33	
	19	9½	126	117.34	16	17	55	83	40	2.03	
	21	10½	138	129.26	16	17	55	83	40	2.23	
	23	11½	150	141.22	16	17	55	83	45	2.56	
25	12½	162	153.20	18	19	55	83	45	2.81		

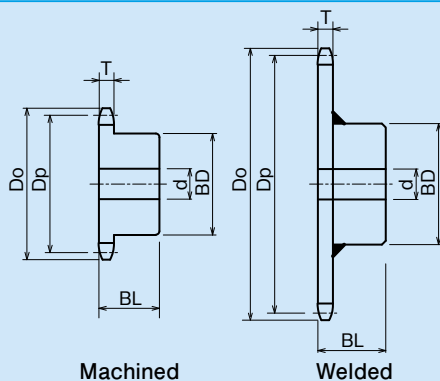

- KCM 2080**
- Chain pitch ..... (P) 50.80 mm
  - Roller link inside width (W) 15.88 mm
  - Roller diameter ..... (Dr) 15.88 mm
  - Teeth width ..... (T) 14.6 mm

TYPE (B-type)	No. of Actual Teeth	No. of Working Teeth	Outside Dia. Do	Pitch Dia. Dp	Shaft Bore Dia. d			Hub Dia. BD	Hub Length BL	Weight (kg)	Construction	Material
					Drill Hole	Min.	Max.					
2080B	13	6½	118	109.31	16	17	46	70	40	1.62	Machined	Carbon steel for machine structural use / Induction hardened tooth end
	15	7½	135	124.90	20	21	60	88	40	2.34		
	17	8½	151	140.63	20	21	63	93	40	2.48		
	19	9½	167	156.45	20	21	63	93	40	3.24		
	21	10½	184	172.35	20	21	63	93	40	3.68		
	23	11½	200	188.29	26	27	75	107	45	4.88		
25	12½	216	204.27	26	27	75	107	45	5.43	Welded	Common steel	

## ● B-type for R-Rollers

R-roller sprocket is a sprocket exclusively designed for double pitch chain for R-roller.

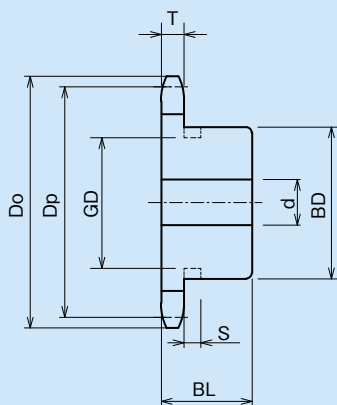

Machined

No. of Teeth	Groove Dimensions	
	Width	Dia.
7	6	35
8	6	43

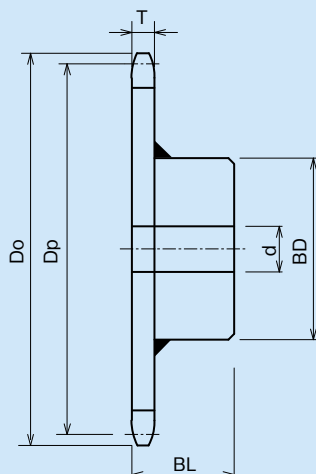

Welded

No. of Teeth	Groove Dimensions	
	Width	Dia.
7	7	45
8	7	56

- KCM 2042**
- Chain pitch ..... (P) 25.4 mm
  - Roller link inside width (W) 7.95 mm
  - Roller diameter ..... (Dr) 15.88 mm
  - Teeth width ..... (T) 7.2 mm

TYPE (B-type)	No. of Working Teeth	Outside Dia. Do	Pitch Dia. Dp	Shaft Bore Dia. d			Hub Dia. BD	Hub Length BL	Weight (kg)	Construction	Material
				Drill Hole	Min.	Max.					
2042B	7	68	58.54	14	15	22	★40	25	0.26	Machined	Carbon steel for machine structural use
	8	77	66.37	14	15	28	★48	25	0.37		
	9	85	74.26	14	15	32	52	25	0.47		
	10	93	82.20	15	16	42	63	25	0.70		
	11	102	90.16	15	16	42	63	25	0.77		
	12	108	98.14	15	16	42	63	25	0.84		
	13	118	106.14	16	17	42	63	25	0.97		
	14	127	114.15	16	17	42	63	25	1.07		
	15	135	122.17	20	21	45	68	28	1.26		
	16	143	130.20	20	21	45	68	28	1.30		
	17	151	138.23	20	21	45	68	28	1.35		
	18	159	146.27	20	21	45	68	28	1.45		
	19	167	154.32	20	21	45	68	28	1.60		
	20	176	162.37	20	21	45	68	28	1.80		
	21	183	170.42	20	21	48	73	32	1.91		
22	192	178.48	26	27	48	73	32	2.03			
23	200	186.54	26	27	48	73	32	2.15			
24	208	194.60	26	27	48	73	32	2.28			
25	216	202.66	26	27	48	73	32	2.42			
26	224	210.72	26	27	48	73	32	2.56			
28	241	226.86	26	27	48	73	32	2.87			
30	257	243.00	26	27	48	73	32	3.19			
32	273	259.14	26	27	55	83	32	4.04			

- NOTES: - Shaft bore, key, tap, and the like will be processed to meet your request.  
 - Sprockets other than those listed above are also manufactured. Contact us.  
 - Sprockets marked with star ★ are provided with groove on hub perimeter. See Groove Dimensions Table.

- KCM 2052**
- Chain pitch ..... (P) 31.75 mm
  - Roller link inside width (W) 9.53 mm
  - Roller diameter ..... (Dr) 19.05 mm
  - Teeth width ..... (T) 8.7 mm

TYPE (B-type)	No. of Working Teeth	Outside Dia. Do	Pitch Dia. Dp	Shaft Bore Dia. d			Hub Dia. BD	Hub Length BL	Weight (kg)	Construction	Material
				Drill Hole	Min.	Max.					
2052B	7	85	73.18	20	21	30	★50	28	0.46	Machined	Carbon steel for machine structural use
	8	96	82.97	20	21	40	★60	28	0.67		
	9	106	92.83	20	21	42	66	28	0.86		
	10	116	102.75	20	21	48	73	28	1.10		
	11	127	112.70	20	21	48	73	28	1.20		
	12	138	122.67	20	21	48	73	28	1.30		
	13	148	132.67	20	21	48	73	28	1.50		
	14	158	142.68	20	21	48	73	28	1.90		
	15	168	152.71	20	21	48	73	28	2.00		
	16	179	162.74	20	21	48	73	28	2.30		
	17	189	172.79	20	21	55	83	35	2.45		
	18	199	182.84	20	21	55	83	35	2.75		
	19	209	192.90	20	21	55	83	35	2.95		
	20	220	202.96	20	21	55	83	35	3.15		
	21	229	213.03	20	21	55	83	35	3.25		
22	240	223.10	26	27	55	83	35	3.48			
23	250	233.17	26	27	55	83	35	3.71			
24	260	243.25	26	27	55	83	35	3.96			
25	270	253.32	26	27	55	83	35	4.22			
26	281	263.41	26	27	55	83	35	4.49			
28	301	283.57	26	27	55	83	35	5.06			
30	321	303.75	26	27	55	83	35	5.68			

- NOTES: - Shaft bore, key, tap, and the like will be processed to meet your request.  
 - Sprockets other than those listed above are also manufactured. Contact us.  
 - Sprockets marked with star ★ are provided with groove on hub perimeter. See Groove Dimensions Table.

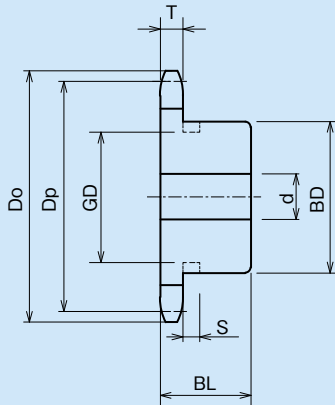

Machined

No. of Teeth	Groove Dimensions	
	Width	Dia.
7	10	56
8	10	68

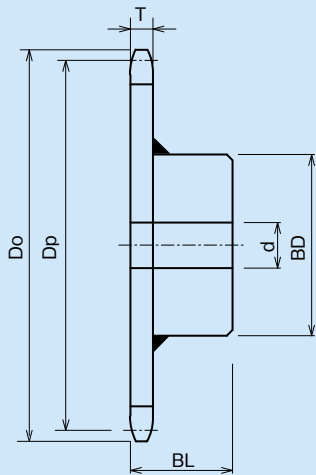

Welded

- KCM 2062**
- Chain pitch ..... (P) 38.10 mm
  - Roller link inside width (W) 12.70 mm
  - Roller diameter ..... (Dr) 22.23 mm
  - Teeth width ..... (T) 11.7 mm

TYPE (B-type)	No. of Working Teeth	Outside Dia. Do	Pitch Dia. Dp	Shaft Bore Dia. d			Hub Dia. BD	Hub Length BL	Weight (kg)	Construction	Material
				Drill Hole	Min.	Max.					
2062B	7	102	87.81	20	21	40	★60	40	0.97	Machined	Carbon steel for machine structural use
	8	115	99.56	20	21	50	★75	40	1.44		
	9	128	111.40	20	21	50	80	40	1.80		
	10	140	123.29	23	24	55	80	45	2.50		
	11	153	135.23	25	26	55	80	45	2.60		
	12	165	147.21	25	26	55	80	45	2.80		
	13	177	159.20	25	26	55	83	45	3.10	Welded	Common steel
	14	190	171.22	25	26	55	83	45	3.60		
	15	202	183.25	25	26	55	83	45	3.90		
	16	214	195.29	25	26	55	83	45	4.20		
	17	227	207.35	25	26	63	93	45	4.60		
	18	239	219.41	25	26	63	93	45	5.00		
	19	251	231.48	25	26	63	93	45	5.50		
	20	263	243.55	25	26	63	93	45	6.00		
	21	276	255.63	25	26	63	93	45	5.89		
	22	288	267.72	26	27	63	93	45	6.34		
24	312	291.90	26	27	63	93	45	7.28			
25	324	303.99	26	27	63	93	45	7.77			
26	337	316.09	26	27	63	93	45	8.77			
28	361	340.29	26	27	63	93	45	9.90			
30	385	364.49	26	27	63	93	45	11.20			

- NOTES:
- Shaft bore, key, tap, and the like will be processed to meet your request.
  - Sprockets other than those listed above are also manufactured. Contact us.
  - Sprockets marked with star ★ are provided with groove on hub perimeter. See Groove Dimensions Table.

- KCM 2082**
- Chain pitch ..... (P) 50.80 mm
  - Roller link inside width (W) 15.88 mm
  - Roller diameter ..... (Dr) 28.58 mm
  - Teeth width ..... (T) 14.6 mm

TYPE (B-type)	No. of Working Teeth	Outside Dia. Do	Pitch Dia. Dp	Shaft Bore Dia. d			Hub Dia. BD	Hub Length BL	Weight (kg)	Construction	Material
				Drill Hole	Min.	Max.					
2082B	7	136	117.08	22	23	50	76	40	1.85	Machined	Carbon steel for machine structural use
	8	153	132.75	22	23	60	93	40	2.64		
	9	170	148.53	26	27	65	110	40	3.56		
	10	187	164.39	26	27	63	93	40	3.29		
	11	204	180.31	26	27	75	107	45	4.42		
	12	220	196.28	26	27	75	107	45	4.94		
	13	237	212.27	26	27	75	107	45	5.46	Welded	Common steel
	14	253	228.29	26	27	75	107	45	6.09		
	15	269	244.33	30	31	75	107	45	6.70		
	16	286	260.39	30	31	75	107	45	7.42		
	17	302	276.46	30	31	75	107	45	8.12		
	18	319	292.55	30	31	80	117	50	9.76		
	19	335	308.64	30	31	80	117	50	10.56		
	20	351	324.74	30	31	80	117	50	11.46		
	24	416	389.19	35	36	80	117	50	16.30		
	25	433	405.32	35	36	80	117	50	17.50		
26	449	421.45	35	36	80	117	50	18.70			
28	481	453.72	35	36	80	117	50	21.20			
30	514	485.99	35	36	80	117	50	24.00			

- NOTES:
- Shaft bore, key, tap, and the like will be processed to meet your request.
  - Sprockets other than those listed above are also manufactured. Contact us.



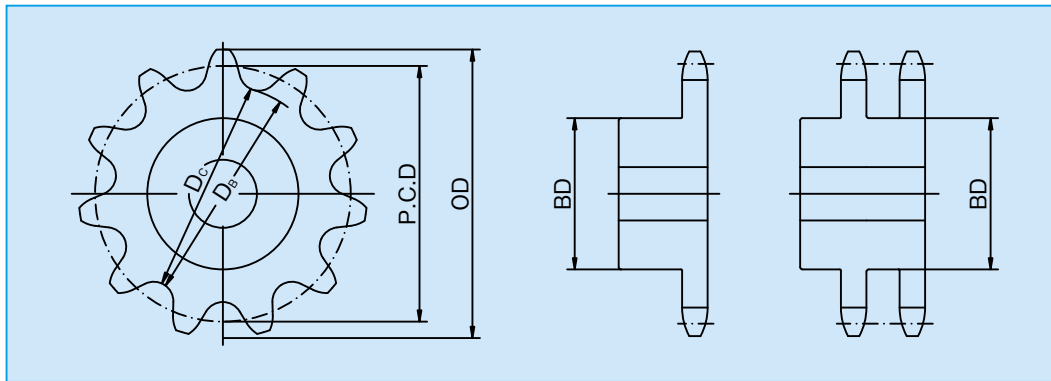

## Number of Teeth of Sprocket

Sprockets with 17 teeth or more are typically used but it is recommended to use sprockets with as many teeth as possible if space and operating condition allow it.

Items	Equations
Chain pitch Roller diameter Sprocket speed Chain speed,	$P$ (mm) $D_r$ (mm) $n$ (r/min) $v$ (m/min)
Number of teeth of sprocket $N$ Pitch circle diameter PCD Standard outside diameter OD Teeth bottom diameter $D_B$	$N = \frac{1000v}{P \cdot n}$ $P.C.D = P \sin \frac{180^\circ}{N}$ $OD = P \left( 0.6 + \cot \frac{180^\circ}{N} \right)$ $D_B = P.C.D - D_r$
Teeth bottom-to-bottom distance of sprocket with an even number of teeth $D_C$ Teeth bottom-to-bottom distance of sprocket with an odd number of teeth $D_C$	$D_C = D_B$ $D_C = P.C.D \left( \cos \frac{90^\circ}{N} \right) - D_r$
Tolerance of bottom-to-bottom distance between teeth (+) Tolerance = 0.000 (-) Tolerance = $0.001P\sqrt{N} + 0.76$ Max. Hub diameter $DH = P \left( \cot \frac{180^\circ}{N} - 1 \right) - 0.76$	

Diameter, teeth bottom-to-bottom distance, and pitch circle diameter can be easily found using Table 1.

Pitch circle diameter (PCD) can be calculated by the equation:  $PCD = \text{Factor} \times \text{Pitch } (P)$ .

Example

To calculate the pitch circle diameter of the sprocket KCM40 ( $P=12.70$ ) with 30 teeth:

$$9.5668 \text{ (factor)} \times 12.70 \text{ (P)} \\ = 121.49836$$

Therefore, the pitch circle diameter is 121.50.

## Hardening of Tooth End

Teeth of sprockets are required for toughness and abrasion resistance because the teeth are impacted by engagement with rollers and abrasion takes place by sliding with rollers.

In special cases of applications subject to severe abrasion or significant impact load, carbon steel is used and induced-hardened.

Induced hardening is required to use in the following operating environment.

- Smaller sprockets with 20 teeth or less are used at 1/6 or higher the max speed specified in Chain Power Transmission Table.
- Smaller sprockets is used at a speed ratio 4:1 or more.
- Smaller sprockets subject to heavy load at low speed.
- Sprockets are used in the atmosphere where teeth are subject to severe abrasion.
- In the operating conditions where frequent starts and stops or sudden reversing transmission take place.

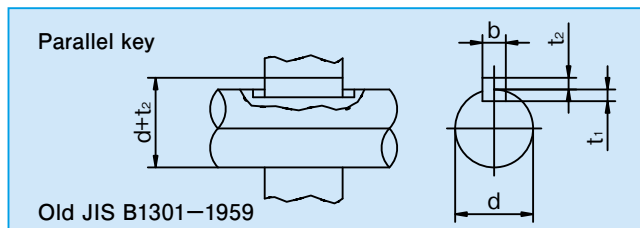

Shaft Diameter d	Nominal Dimensions of Key Width × Height b × (t <sub>2</sub> + t <sub>1</sub> )	Depth of key groove	
		Shaft: t <sub>1</sub>	Hub: d+t <sub>2</sub>
10 or more to 13 or less	4 × 4	2.5	d + 1.5
Exceeding 13 to 20	5 × 5	3.0	d + 2.0
20 " 30 "	7 × 7	4.0	d + 3.0
30 " 40 "	10 × 8	4.5	d + 3.5
40 " 50 "	12 × 8	4.5	d + 3.5
50 " 60 "	15 × 10	5.0	d + 5.0
60 " 70 "	18 × 12	6.0	d + 6.0
70 " 80 "	20 × 13	7.0	d + 6.0
80 " 95 "	24 × 16	8.0	d + 8.0
95 " 110 "	28 × 18	9.0	d + 9.0
110 " 125 "	32 × 20	10.0	d + 10.0
125 " 140 "	35 × 22	11.0	d + 11.0
140 " 160 "	38 × 24	12.0	d + 12.0
160 " 180 "	42 × 26	13.0	d + 13.0
180 " 200 "	45 × 28	14.0	d + 14.0
200 " 224 "	50 × 31.5	16.0	d + 15.5
224 " 250 "	56 × 35.5	18.0	d + 17.5

## Dimensions of Drill Hole and Drilling of Shaft Bore

Single strand and double strand standard sprockets are provided with holes drilled 2.10 mm smaller than the minimum diameter of shaft listed. When you need to drill shaft bore, the bore must be determined based on the outside diameter or teeth bottom diameter.

Otherwise specified on order, key groove is machined to JIS and the shaft bore is drilled to tolerance H7.

Tolerance H7 Table

(unit: mm)

Diameter $\phi D$	H7
5 ~ 6	0 ~ +0.018 (H8)
7 ~ 10	0 ~ +0.015
11 ~ 18	0 ~ +0.018
19 ~ 30	0 ~ +0.021
31 ~ 50	0 ~ +0.025
51 ~ 80	0 ~ +0.030

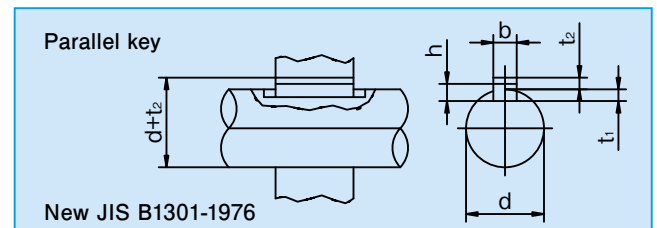

Shaft Diameter d	Nominal Dimensions of Key Width × Height b × h	Depth of key groove	
		Shaft: t <sub>1</sub>	Hub: d+t <sub>2</sub>
6 or more to 8 or less	2 × 2	1.2	d + 1.0
Exceeding 8 to 10	3 × 3	1.8	d + 1.4
10 " 12 "	4 × 4	2.5	d + 1.8
12 " 17 "	5 × 5	3.0	d + 2.3
17 " 22 "	6 × 6	3.5	d + 2.8
22 " 30 "	8 × 7	4.0	d + 3.3
30 " 38 "	10 × 8	5.0	d + 3.3
38 " 44 "	12 × 8	5.0	d + 3.3
44 " 50 "	14 × 9	5.5	d + 3.8
50 " 58 "	16 × 10	6.0	d + 4.3
58 " 65 "	18 × 11	7.0	d + 4.4
65 " 75 "	20 × 12	7.5	d + 4.9
75 " 85 "	22 × 14	9.0	d + 5.4
85 " 95 "	25 × 14	9.0	d + 5.4
95 " 110 "	28 × 16	10.0	d + 6.4
110 " 130 "	32 × 18	11.0	d + 7.4
130 " 150 "	36 × 20	12.0	d + 8.4
150 " 170 "	40 × 22	13.0	d + 9.4
170 " 200 "	45 × 25	15.0	d + 10.4
200 " 230 "	50 × 28	17.0	d + 11.4